

Data Sheet

# PLUS+1 Expansion Module

## IOX024-020



### Mobile Machine Management

This product is an element of the flexible, powerful and expandable PLUS+1<sup>®</sup> family of mobile machine management products. Expansion modules provide cost-effective additional I/O to mobile machine control systems.

### Product Highlights

Expansion modules are associated with a PLUS+1<sup>®</sup> controller. PLUS+1<sup>®</sup> GUIDE (Graphical User Integrated Development Environment) applications running in the controller read inputs from and write outputs to expansion module pins as if the pins are physically located on the controller. Pin properties are configured in the controller's GUIDE application.

PLUS+1<sup>®</sup> compliance eliminates need for the system designer to write CAN transmit and receive messages in both the controller and associated expansion modules.

### Application Development

Users configure expansion modules using PLUS+1<sup>®</sup> GUIDE. This Microsoft<sup>®</sup> Windows<sup>®</sup>-based development environment features a user-friendly, field proven, icon-based graphical programming tool, application downloader, and service/ diagnostic tool.

### Features

- 24 pins: (2) individually keyed DEUTSCH DTM 12 pin connectors
- 9 to 36 Vdc power supply, monitored internally
- 1 CAN 2.0B port, the fixed range analog input can be configured as the shield pin
- 3 mounting alternatives: stack, end, or side
- CE compliant
- 8 inputs: (5) universal (DIN/AIN/FreqIN) that the user can define as either:
  - *Analog*: with configurable ranges 0 to 5.25 Vdc or 0 to 36 Vdc; *Digital*: pull up (5 Vdc), pull down (0 Vdc) or pull to center (2.5 Vdc); *Frequency (timing)*: 1 Hz to 10 kHz
  - (2) digital (DIN) configurable as pull up (5 Vdc), pull down (0 Vdc)
  - (1) fixed-range analog (AIN/CAN shield) 0 to 5.25 Vdc or CANshield pin
  - 8 outputs: (8) universal (PWMOUT/DOUT/PVGOUT) that the user can define as either: *Digital*: (3 A), configurable as source or sink; *PWM*: (30 to 4000 Hz), configurable as open or closed loop with current control; *Analog voltage*: open loop PWM at 4000 Hz
- Any PWMOUT/DOUT/PVGOUT can be used to provide reference power to one PVG valve
- Power supply for external sensors rated at 5 Vdc to 200 mA and regulated internally



**IOX024-020 Dimensions and Pin Assignments**

mm [in]

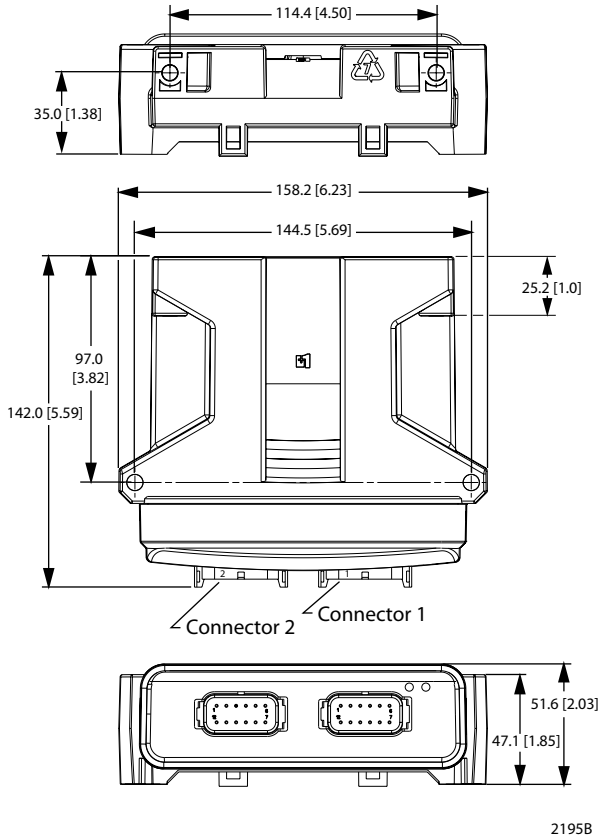

**24 Pin**

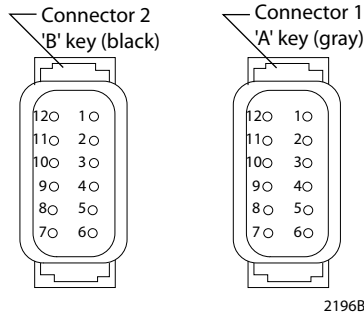

Use care when wiring mating connector. Above pinouts are for device pins.

| Pin    | Controller function | Pin    | Controller function   |
|--------|---------------------|--------|-----------------------|
| C2-P1  | DIN/AIN/FreqIN      | C1-P1  | Power ground -        |
| C2-P2  | PWMOUT/DOUT/PVGOUT  | C1-P2  | Power supply +        |
| C2-P3  | PWMOUT/DOUT/PVGOUT  | C1-P3  | CAN +                 |
| C2-P4  | PWMOUT/DOUT/PVGOUT  | C1-P4  | CAN -                 |
| C2-P5  | PWMOUT/DOUT/PVGOUT  | C1-P5  | AIN/CAN shield        |
| C2-P6  | PWMOUT/DOUT/PVGOUT  | C1-P6  | DIN                   |
| C2-P7  | PWMOUT/DOUT/PVGOUT  | C1-P7  | DIN                   |
| C2-P8  | PWMOUT/DOUT/PVGOUT  | C1-P8  | 5 Vdc sensor power +  |
| C2-P9  | PWMOUT/DOUT/PVGOUT  | C1-P9  | Sensor power ground - |
| C2-P10 | PWMOUT/DOUT/PVGOUT  | C1-P10 | DIN/AIN/FreqIN        |
| C2-P11 | Power supply +      | C1-P11 | DIN/AIN/FreqIN        |
| C2-P12 | Power supply +      | C1-P12 | DIN/AIN/FreqIN        |

**Caution**

PCB damage may occur. Connect all device power supply + pins to battery +. This device is not field serviceable. Opening the device housing voids the warranty.

**Specifications**

|                                  |                                |
|----------------------------------|--------------------------------|
| <b>Supply voltage</b>            | 9 to 36 Vdc                    |
| <b>Operating temp. (ambient)</b> | -40°C to 70°C [-40°F to 158°F] |
| <b>Storage temp.</b>             | -40°C to 85°C [-40°F to 185°F] |
| <b>Programming temp.</b>         | 0°C to 70°C [32°F to 158°F]    |
| <b>IP rating</b>                 | IP 67                          |
| <b>EMI/RFI rating</b>            | 100 V/m                        |
| <b>Weight</b>                    | 0.40 kg [0.88 lb]              |
| <b>Vibration</b>                 | IEC 60068-2-64                 |
| <b>Shock</b>                     | IEC 60068-2-27 test Ea         |
| <b>Max. current, sourcing</b>    | 24 A                           |
| <b>Max. current, sinking</b>     | 8 A                            |

**Ordering Information and Related Products**

| Description                                   | Part number             |                         |
|---|-------------------------|-------------------------|
| IOX024-020                                    | 11062251                |                         |
| CG150 CAN/USB Gateway                         | 10104136                |                         |
| DEUTSCH mating connector bag assembly         | 10102025 (16 to 20 AWG) | 10100944 (20 to 24 AWG) |
| PLUS+1 <sup>®</sup> GUIDE single user license | 10101000                |                         |

Danfoss can accept no responsibility for possible errors in catalogues, brochures and other printed material. Danfoss reserves the right to alter its products without notice. This also applies to products already on order provided that such alterations can be made without changes being necessary in specifications already agreed. All trademarks in this material are property of the respective companies. Danfoss and the Danfoss logotype are trademarks of Danfoss A/S. All rights reserved.